

BARATHRUM



PCP AIR RIFLES
USER MANUEL

ABOUT US

With foundations laid down since the year 1994, Barathrum Arms has been a constant name in the Turkish local market for two decades since it was founded. Based on the positive reviews that were received during this period, Barathrum Arms decided to open its doors to the outside world since the year 2014. Till today, Barathrum Arms is committed to producing the highest quality products for our clients all over the World.

With a 1,000 square meter factory located in Konya, Barathrum Arms Company has been expanding gradually ever since it was founded with the help of our ever present and ever hard working employees who put their passion and craftsmanship into producing high quality products all the time. On top of this products go through a high standard quality control system that makes sure the product are manufactured under the CIP restrictions.

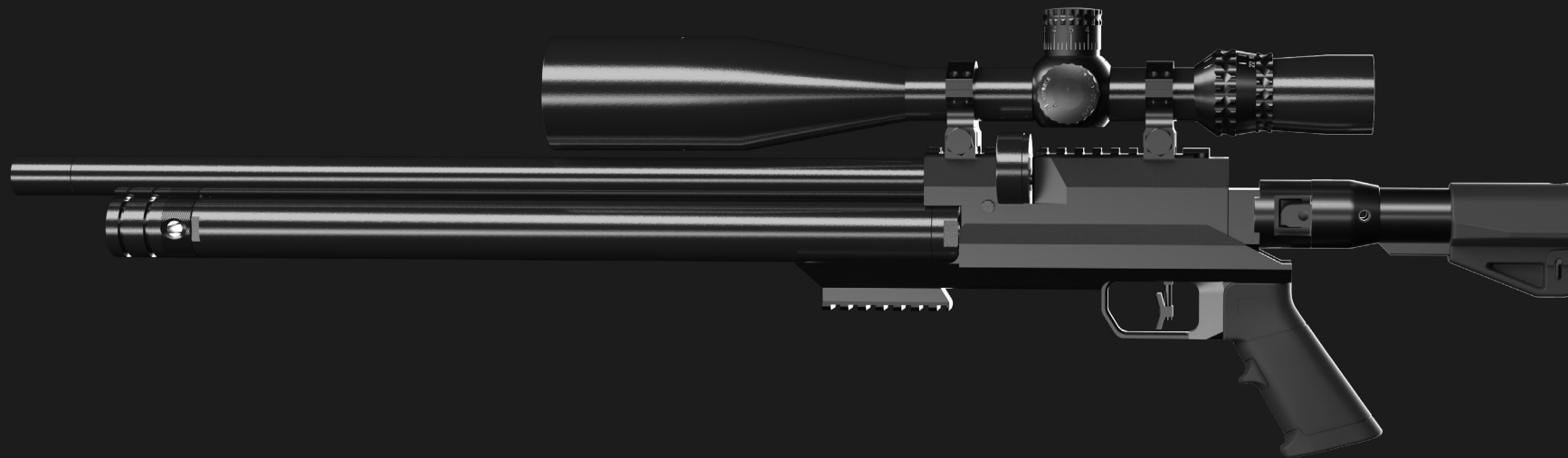

WARNING

CAUTION!

In case of surface parallel or sky shoots, you may cause damage to 1000 yards (1km) around you with the effect of the acceleration or free fall effect.

CAUTION!

This is not a toy. Only persons of at least 18 years old with mental and physical capability can use it.

CAUTION!

Charge with the air that you are sure to have been dried with electrical or granule type dryer. In case of filling with original pump avoid rapid movements. Otherwise, lower side of the pump may go out of the ideal working temperature and sweat which will cause humid charging of your air tube.

A CAUTION!

Your airgun's safety should always be on (safety active) and you should turn off the safety only right before the ideal source line to the target. (Safety passive)

WARNING

A CAUTION!

Do not force your air tank to open (Demount). Do not use any tank that has been tampered due to falling or various reasons.

CAUTION!

Obey the laws, regulations and rules that are in place in the relevant country, province, district or hunting ground whether private or public.

ALWAYS REMEMBER THE FOLLOWING PRECAUTIONS

- Try not to go shooting alone.
- Never use the airgun if you are intoxicated or under the influence of drugs.
- There is high pressure air inside your shotgun that is charged with the logic of squeezing.
- Even if there is no pressure sign on the manometer, never disassemble the pressurized tube.
- Bring the safety on before interrupting your shotgun in any way and never point the barrel to yourself under any circumstance.
- Only use cotton dry cloth to clean any dirt inside the barrel for various reasons (humidity, dust, etc.)
- You may observe that the groupment performance of the shotgun has reduced if you interrupt your shotgun due to dirt barrel outside the instructions given by the manufacturer (hard objects, cleaning with gear type mineral and synthetic oils, etc.) and cause your shotgun to go out of the warranty.

ALWAYS REMEMBER THE FOLLOWING PRECAUTIONS

- In your shotgun, some of the parts work with larger tolerances while others are narrower. For this reason, use only synthetic or mineral base oil with high viscosity not creating filling effect.
- Your shotgun has been designed not to cause any sliding effect with corrosion.
- Various acids and bleaches inside the anti-corrosive oils might damage the tightness equipment and some of the covered surfaces.
- Calculate the areas where pellet might reach in each of your shoot on or off the target. This is extremely important for the safety of yourself and also living and non-living objects around you.
- Do not run or jump with a loaded shotgun. Your barrel should always point a safe distance while jumping through the ditches.
- Always keep your shotgun at safety.
- In case of long storage of your shotgun, always keep your shotgun dry-fired. (The spring type equipment that are always kept tight might undergo tightening or reduction in case of long storage)
- We do not recommend disassembling and reassembling the shotgun unless necessary. Do not disassemble or replace the original parts of your shotgun under any circumstance. Please contact the factory, general distributor or the authorized services of Barathrum throughout Turkey.
- We especially recommend you to act as if your shotgun is always loaded. Even if you are in an empty land of forest, make sure that safety is on and your barrel points a safe direction. The owner of the shotgun shall be responsible for any damage.

THIS REMINDER HAS BEEN WRITTEN TO KEEP YOU AWAY FROM MISTAKES THAT MIGHT CAUSE INJURIES AND EVEN DEATH.

CAUTION!

DANGER OF EXPLOSION!

The air tank poses the explosion risk if it gets heated subject to sunlight for extended period of time. (Max. +40°/Min.-05)

Otherwise, the airgun should be left to cool down in a cool environment. Recommended to be transported under maximum 80 bars pressure during flights.

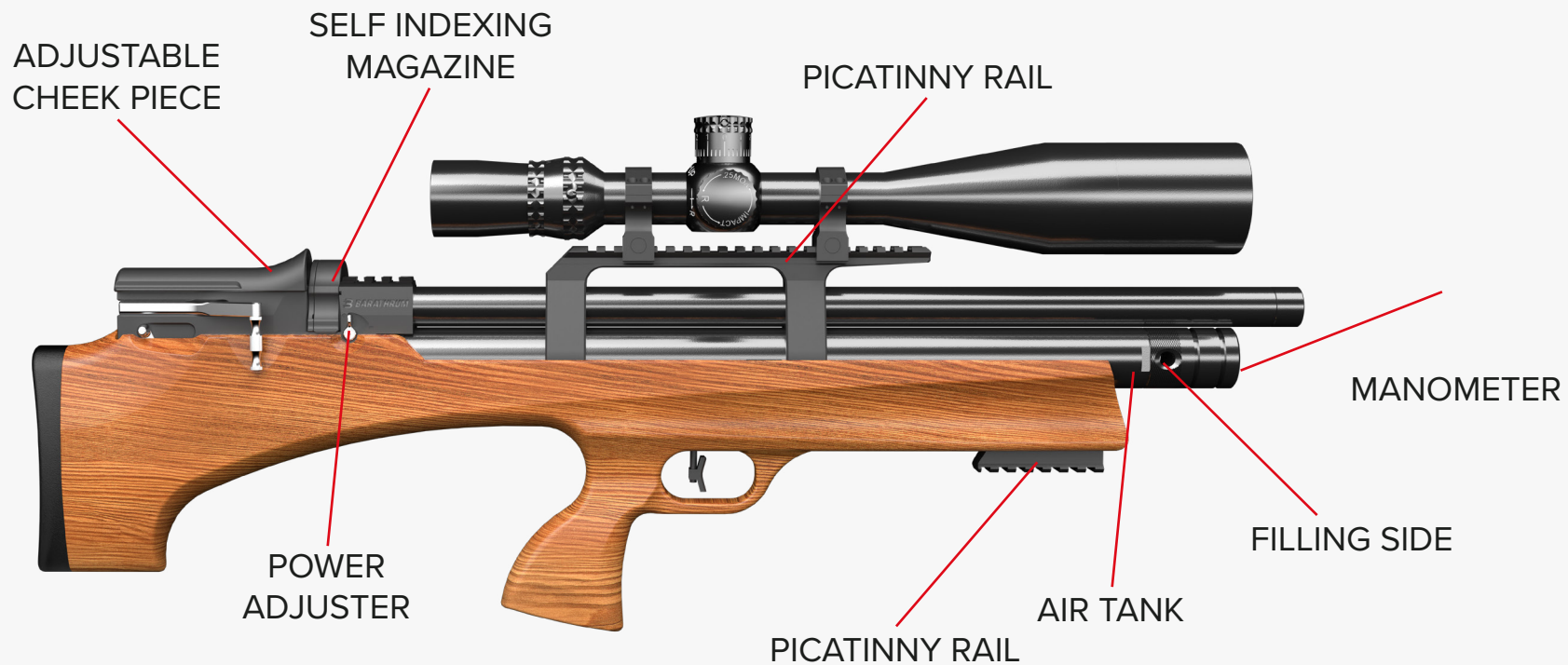

BRT330

PCP AIR RIFLE

BARATHRUM

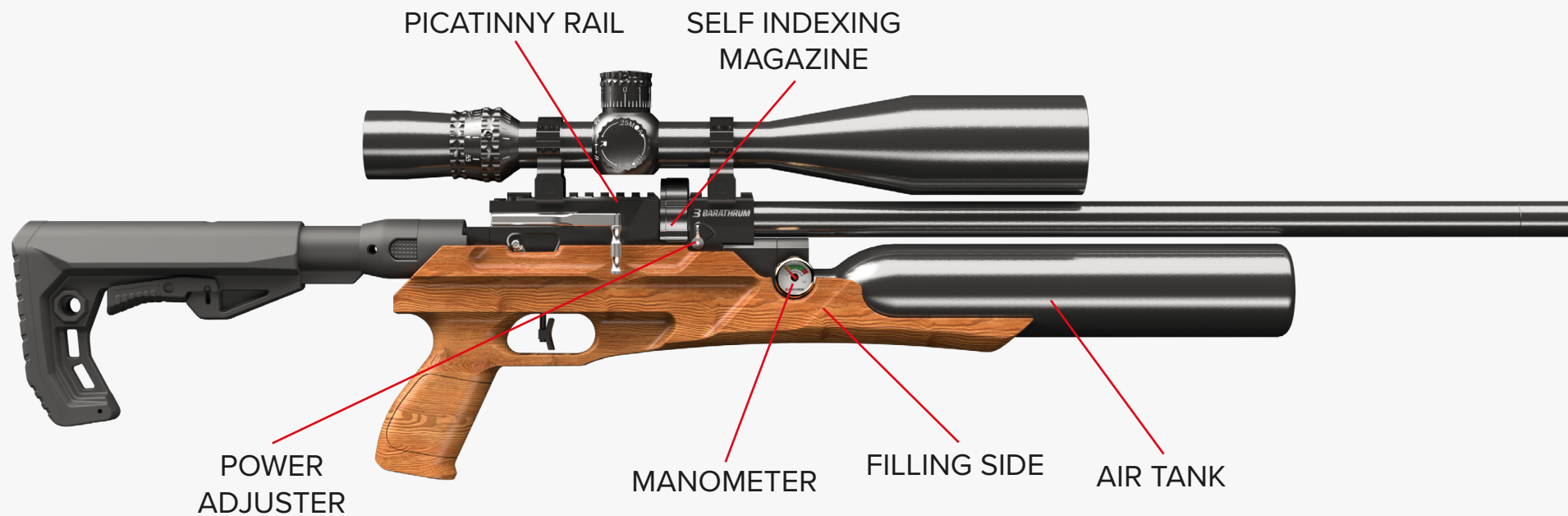

BRT110

PCP AIR RIFLE

B BARATHRUM

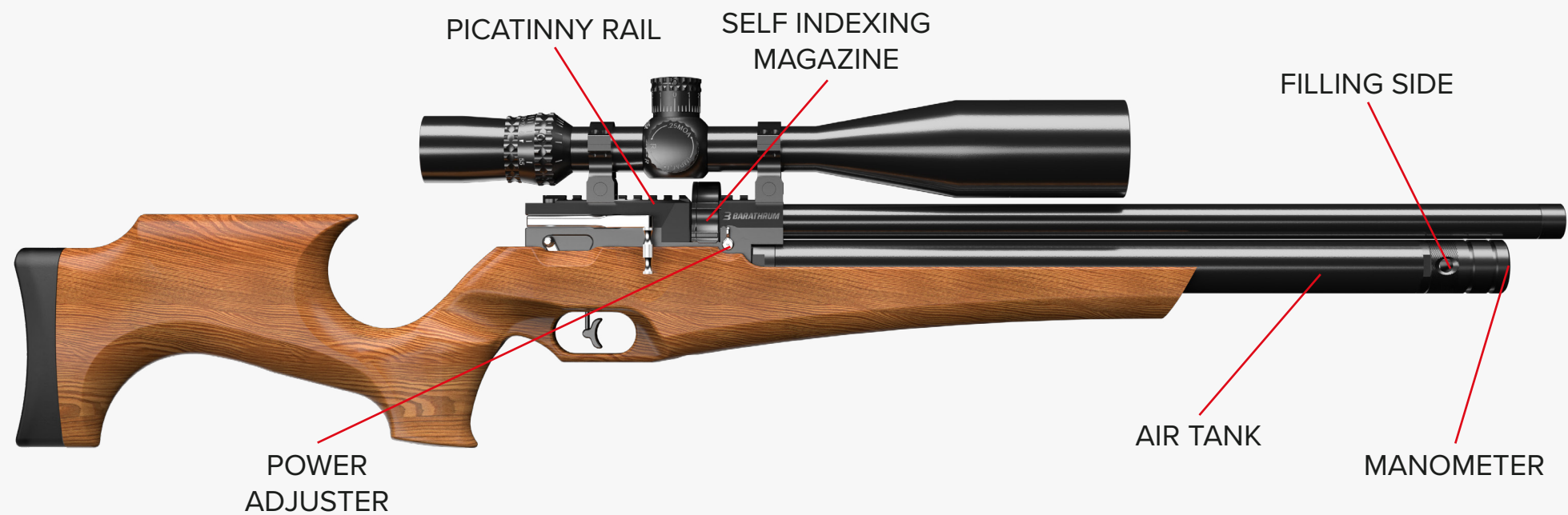

BRT520
PCP AIR RIFLE

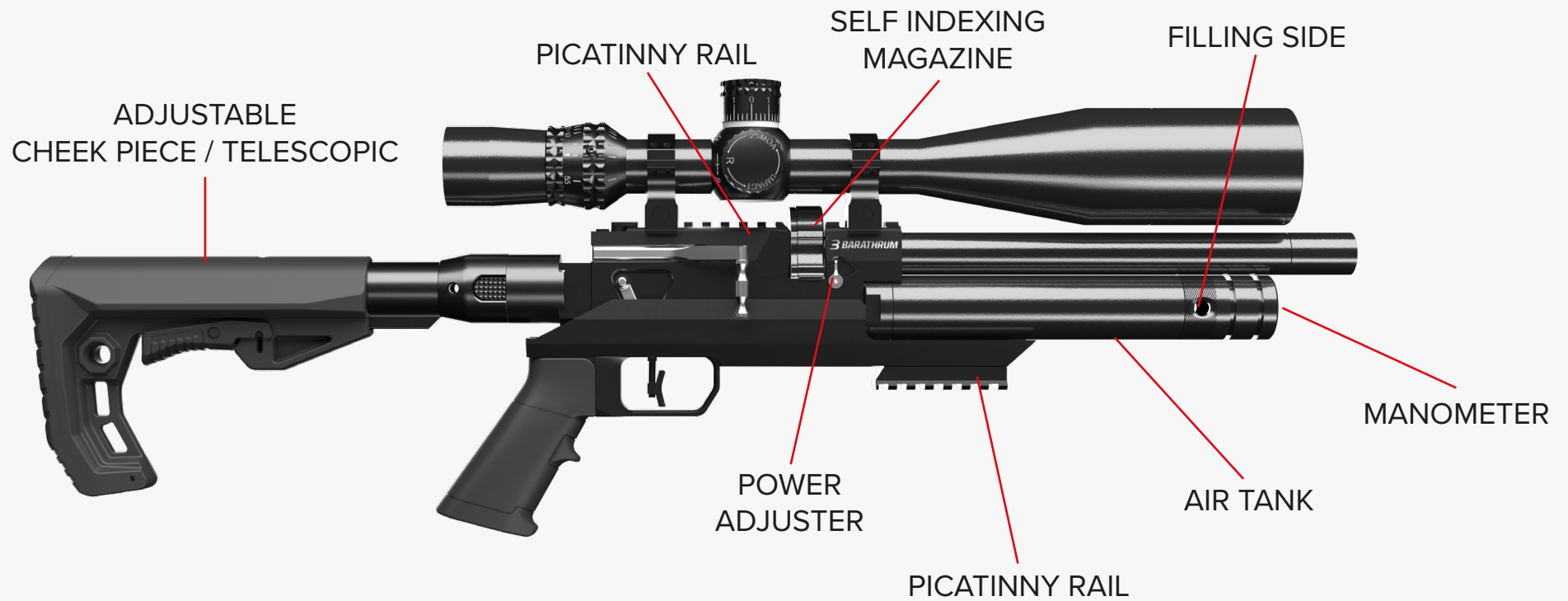

BRT57

PCP AIR RIFLE

GENERAL INFORMATION



SEPARATING THE BODY
You can remove easily with the allen.

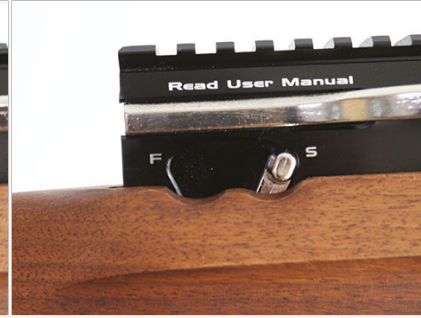
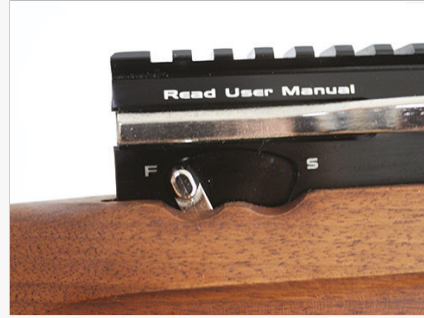

SEPARATING THE BODY
“F” Position means ready to fire.
“S” Position means blocked the fire.



POWER ADJUSTER
Power adjuster valve can only be adjusted from the left side.



MAGAZINE
Remove from right side the magazine that has run out of pellet will not permit new charge.



FILLING THE AIR TANK
The filling outlet is located at the tip of the air tube. Assemble the hose with the filling jack that is provided free of charge inside the box as a standard. If you hear sound of air during the first falling move the jack and enable the orings to be air-proof. (if the leakage continues, orings might be deformed)

GENERAL INFORMATION



BARREL INNER & OUTER O RING

Barrel tightness orings are three totally and 2 of them are outside while: 1 is inside. In case of deformation, please replace with the spare orings that are available inside the packaging.



DISASSEMBLING THE BARREL



Dissassembly the barrel ring from both sides with the allen.



Remove the air stopper.



Remove the silencer.



Remove the barrel slowly.

FILLING THE MAGAZINE



Rotate the idle front cover in the direction of the arrow (clockwise).



Once the glass cover hits the last point, prevent the pushing force of the spring and switch the pellet to the first bed. Once the first pellet prevents the rotation of the inner turret, move the glass cover on the contrary direction and fill the turret.

Note: It will prevent the assembly of turret system, do not force.

SELF INDEXING MAGAZINE

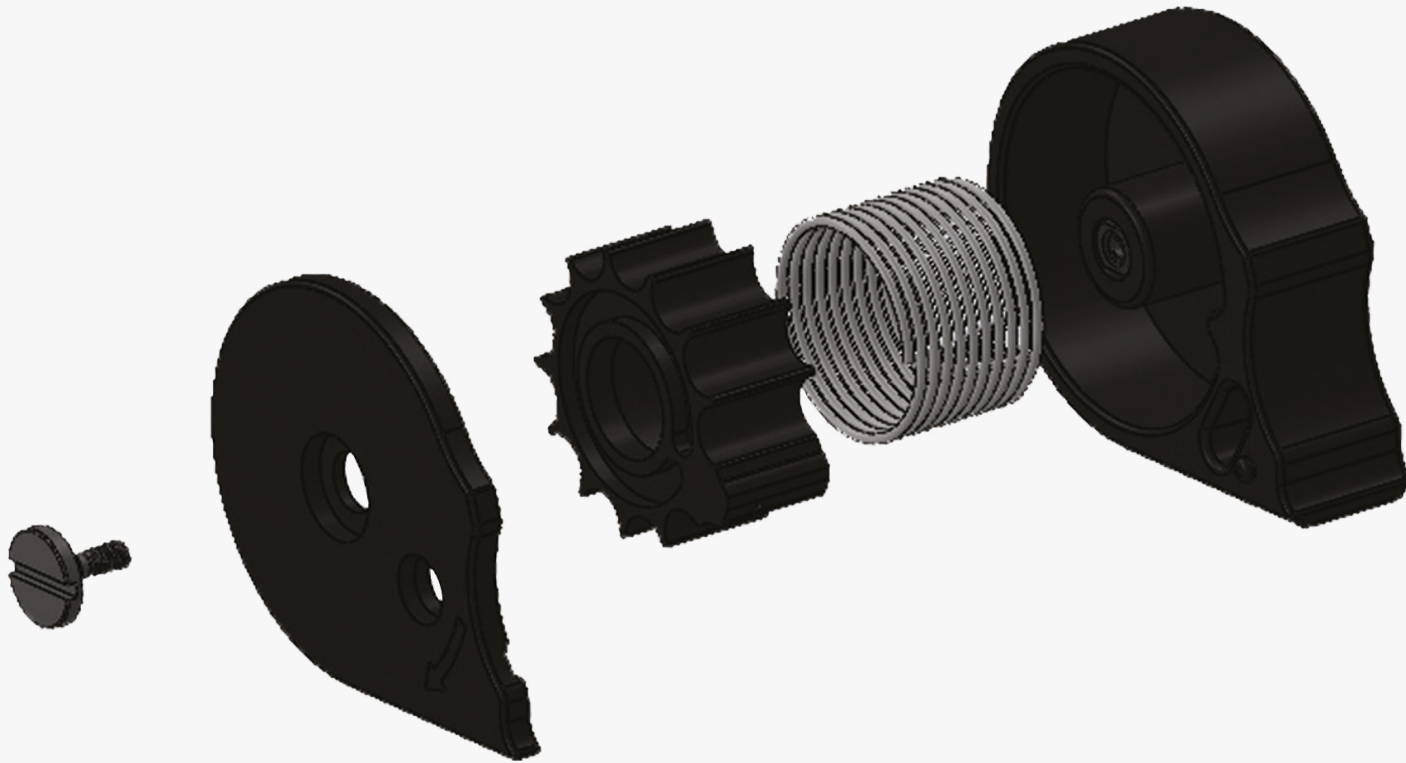

RECEIVER & MECHANISM

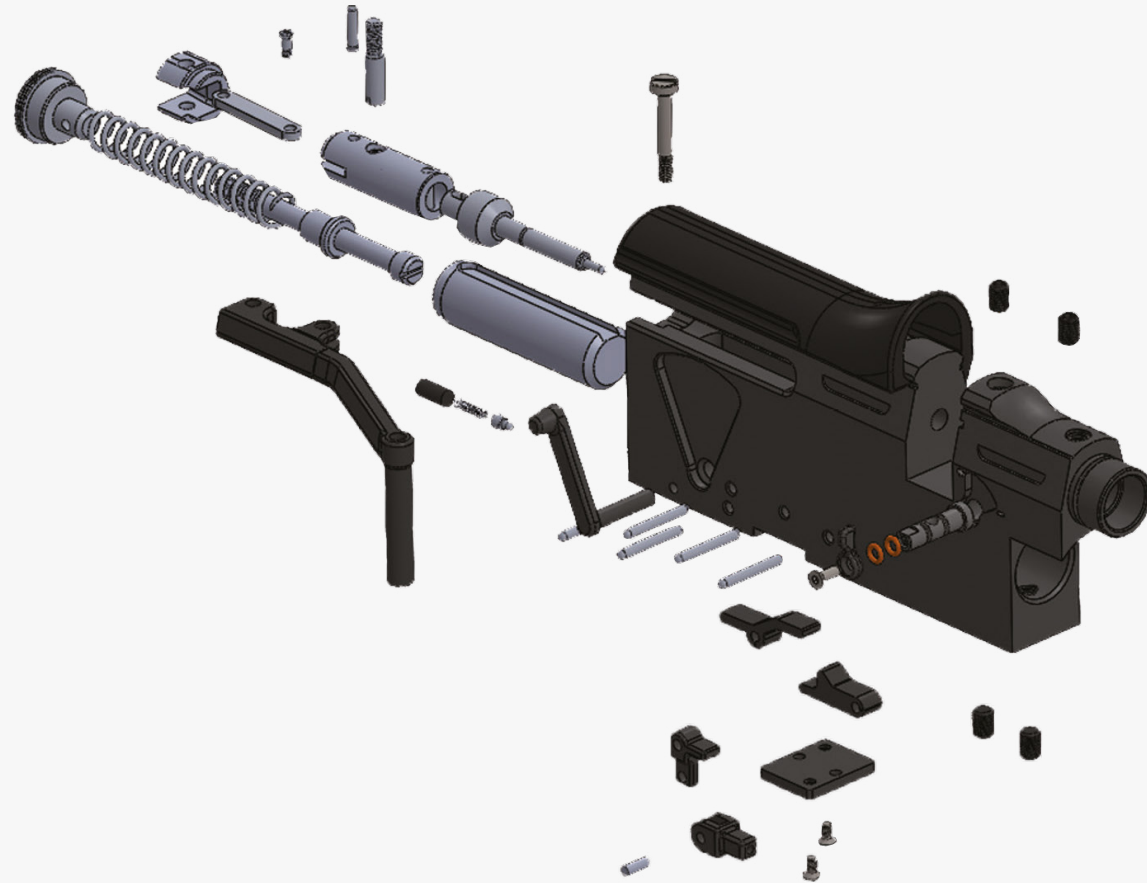



BARATHRUM



www.barathrumsilah.com

Barathrum Savunma Sanayi Tic. Ltd Őti.
Fevzi akmak Mh. Ahmet Peteki Cad. No:17/B
Karatay/Konya



@barathrumgunsofficial